

# Robertshaw®

## RS3110 ECONOMY SERIES RS3210 DIGITAL PROGRAMMABLE THERMOSTATS

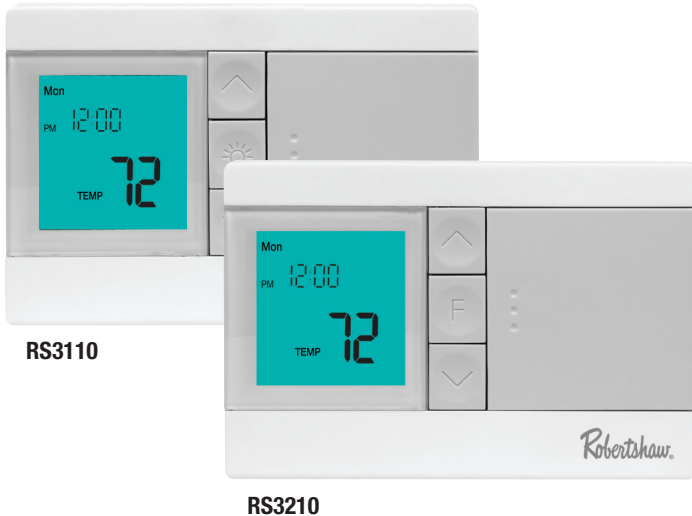

RS3110

RS3210

## Affordable Comfort Control

The Robertshaw® RS3000 thermostat family is *Simply The Right Choice™* when it comes to programmable temperature control that can help reduce energy costs up to 25%.

With the comfort, convenience, and efficiency features that homeowners and contractors want, the RS3000 family provides custom program options in value-packed thermostats for an economical price.

- Simple touch button controls to set weekly programs for summer and winter.
- Automated temperature settings for increased heating/cooling comfort.
- Worry-free memory retention to maintain temperature settings even during power outages.

All RS3000 thermostats are fully compatible with all standard 24V AC heating and cooling systems. The RS3210 offers additional compatibility with single and multi-stage gas/electric furnaces and heat pump systems.

Add in easy installation, expert technical service, and quality you can depend on, and you have the Robertshaw RS3000 thermostat family – *Simply The Right Choice.*



ELECTRIC GAS OIL HEAT PUMP MILLIVOLT  
RS3110 only

**5 - 2 Day Programmable**

**RS3110 – 1 Heat / 1 Cool**

**RS3210 – Multi-Stage 2 Heat / 1 Cool**

## Features and Benefits

### 5 - 2 Day Programming

Set the weekly program once with four time and temperature settings. The four set points are followed for five consecutive days. On the weekend, four different set points can be set for all day comfort.

### Multi-Stage 2 Heat / 1 Cool – RS3210 only

Operates on both multi-stage gas/electric furnaces and heat pumps to reduce inventory needed.

### Bigger Brighter Backlight

Makes viewing and setting the temperature easier.

### Adjustable Temperature Differential

Maintains optimal customer comfort.

### Worry-Free Memory Retention – RS3210 only

Maintains set point and programmed parameters, even during power outages.

### Filter Monitor

Provides notice when filters need changing.

### Low Temperature Freeze Protection – RS3110 only

Turns on heat automatically when temperature goes below 37°F. Protects pipes from freezing.

### Automatic Compressor Short Cycle Protection

Reduces wear and tear of HVAC equipment with this system safeguard.

### Temporary Program Override

Allows for manual temperature adjustment.

### Quick Wire Terminal Block

Uses sturdy wire clamps – no wrap-around of screws for fast and easy installation.

An ISO 9001 – 2008 Certified Company

California Title  
24 Compliant

2 Year  
Limited  
Warranty



### Terminal Designations

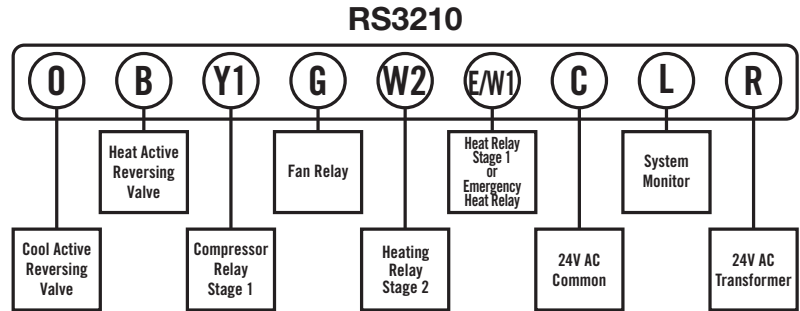
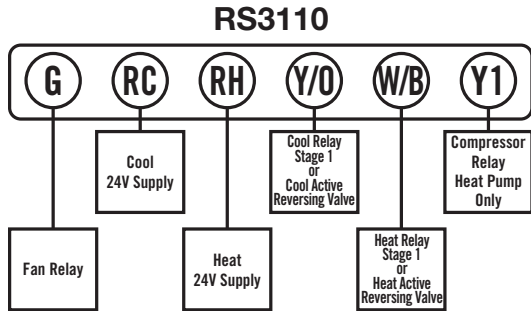

### Technical Specifications

<b>Product Weight</b>	11.2 oz.
<b>Electrical Rating</b>	24V AC (18-30V AC) 1 amp maximum load per terminal 3 amp total maximum load (all terminals combined)
<b>Temp. Control Range</b>	45°F to 95°F (7°C to 35°C)
<b>Accuracy</b>	± 1°F (± 0.5°C)
<b>Power</b>	<b>RS3110</b> – 3.0V DC (2 AA alkaline batteries included) <b>RS3210</b> – 24V AC with battery back-up (2 AA alkaline batteries included)
<b>System Configurations</b>	<b>RS3110</b> – Single stage electric, gas, oil or millivolt heating or heating/cooling systems including single stage heat pump systems <b>RS3210</b> – Multi-stage electric, gas or oil heating or heating/cooling systems including multi-stage heat pump systems
<b>Terminations</b>	<b>RS3110</b> – G, RC, RH, Y/O, W/B, Y1 <b>RS3210</b> – O, B, Y1, G, W2, E/W1, C, L, R

### Replacement Chart

RS3110	
Robertshaw®	8600, 8601
Braeburn®	2000, 2010, 2000NC
Lux	TX500, TX500E
Honeywell	TH2110D
White-Rodgers	1F78-151
RS3210	
Robertshaw®	8625
Braeburn®	2100, 2110, 2200
Lux	HP2110
Honeywell	TH2210D, TH4210D, T8001C, T8001F, T8011F
White-Rodgers	1F72-151

Verify specific application requirements before substitution.

### Shipping Specifications

Individual Carton Dimensions	8" x 1.4" x 4.5"
Master Carton Quantity	6
Master Carton Dimensions	8.46" x 8.07" x 5.71"
Master Carton Weight	4.4 lbs.