

# CONTROL TIPS

A ROBERTSHAW INFORMATIONAL GUIDE

THIS ISSUE

## TROUBLESHOOTING INTERMITTENT IGNITION PROBLEMS

**“Why won't my pilot stay lit?”** If heating service techs have heard customers ask it once, they've heard it a hundred times.

The procedures outlined in this article are for checking out all systems that use an intermittent pilot. (Some of the checks can also be applied to direct spark ignition systems.) These are things that techs should look at as preliminary checks before proceeding with troubleshooting charts and wiring diagrams.

Many checks are visual, or done with the power off and using an ohmmeter.

In order to understand the principles behind many of the checks, it is important for technicians to understand some of the terms that are used. We therefore include a set of definitions on page 4.

The definitions also include two important rules for replacement of existing controls. Under the definition of “time trial for ignition,” there is a rule for replacement that says, “You can replace a module with one with a lesser time”; the “prepurge” rule says that when replacing a module, you may go to a longer time; these two rules give some flexibility when replacing controls.

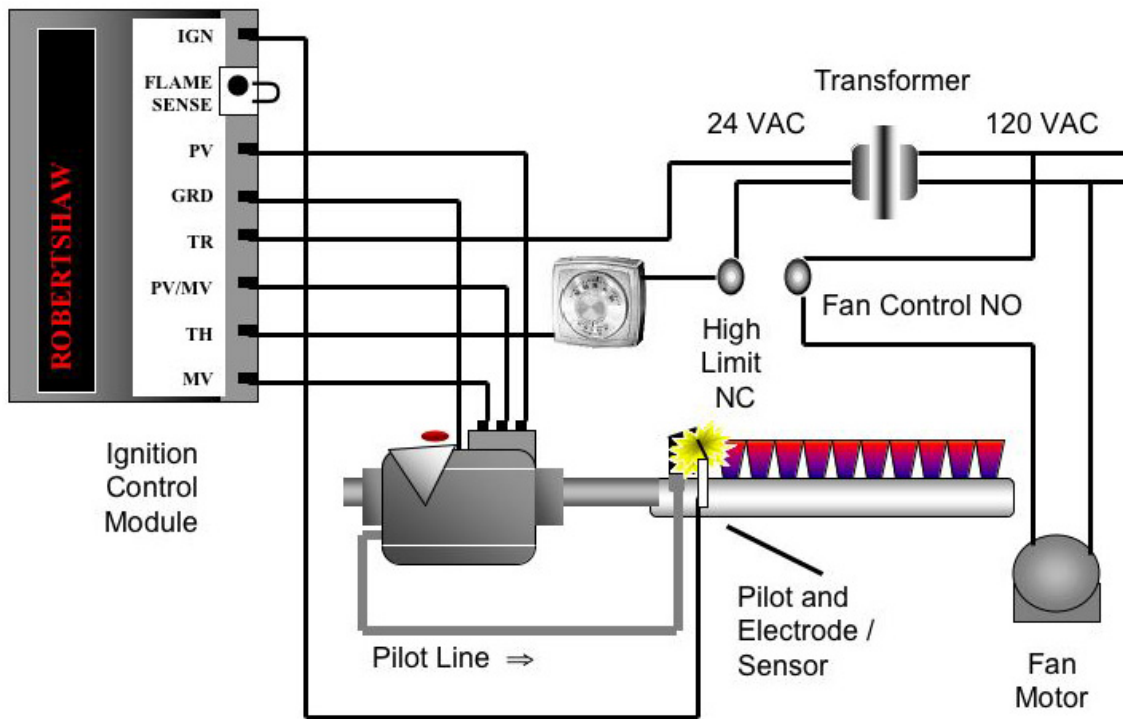

**Pilot Ignition System (IID)**

## A FEW EASY CHECKS TO DO WHEN A PILOT OUTAGE OCCURS

1. Make sure the connections are clean and tight. The “kanthal” sensing/spark rod should be cleaned with a soft, clean emery cloth, or steel wool.

**NOTE:** This is a temporary fix until a new sensor/ignitor can be installed.

2. Check visually to make sure there are no cracks or breaks in the ceramic, that the igniter cable is not dried out or cracked, and that the boot is in good condition. If there is a white, powdery substance on the cable that is the result of ignition cable “outgassing,” replace the cable.
3. Make sure it's not touching any metal surfaces.
4. Make sure it's no more than 36 in. long.
5. Continuity check from the tip of the igniter to the ground; in this case there should not be continuity.

The ignition cable has electrical continuity, so use a continuity tester or the Ohms scale on a multimeter:

1. Check from the tip of the igniter to the connector on the module with it disconnected from the module. You should have continuity. The resistance should be about 0.1 ohm. If you do not have continuity, replace the cable.
2. Run the test lead up and down the tip, looking for increases in resistance or breaks in continuity (sign of a breakdown). If you find this, the igniter should be replaced. The cable on a single-rod system may give you a spark, but will not return a microamp signal due to a break in the cable.
3. Go from the tip of the igniter to ground - this time you should not have continuity. If you do, it is shorted to ground at some point. This would cause a no-spark or weak-spark condition. In order to narrow down what may be grounded, either the cable or something in the module, remove the cable from the module and check from the connector end to ground; if it shows continuity, the cable is grounded. If the previous test showed continuity and this one does not, then the module is shorted.

Check for the intensity of the spark:

1. Remove the igniter cable from the module connection.
2. From the module connection to the igniter cable, an arc should jump at least a 1/2-in. gap.
3. The spark gap on most systems, from the tip of the igniter to the ground connection, is 1/8 in. If the spark will jump across 1/2 in. with good intensity, it should be able to jump across 1/8 in. with no trouble at all.

**NOTE:** Hold the igniter cable with insulated pliers and slowly move the connector on the igniter cable toward the high-voltage connection on the module, with the module energized. The spark should jump across the open gap.

Nuisance shutdowns or no operation at all can be caused by a poor ground or erratic ground (GND) connection.

## IGNITION SYSTEM GROUNDING

From the ground (usually the green wire) terminal on the module, check for continuity to some portion of the boiler or furnace. It is best to check on an unpainted, clean surface.

You should have continuity. If you do not, then the system could operate erratically or not at all.

It may be necessary to establish a good connection to ground by using a wire with a clamp onto the gas line or equipment chassis and connecting it to the ground terminal of the module. All connections should be clean, unpainted, and generally offer good metal-to-metal contact. When you look at the wiring diagram for the equipment, if you see a symbol showing the use of a chassis ground (Figure 2), make sure that you have a good connection.

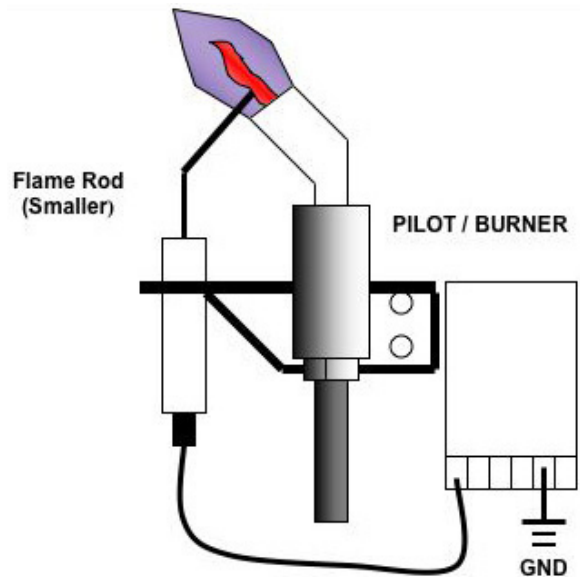

Figure 2

## CHECK POLARITY

This symbol shows the use of a chassis ground. Make sure you have a good connection.

This next check is the beginning of your electrical checks and is best done at the secondary of the 24-V transformer. Many transformers today have terminals on the secondary labeled "C" (for common) and "R" (for hot); this will assist you with this check.

If this check indicates that in fact "R" is 24 V and "C" is 0 V, then the primary polarity is correct. If it indicates the opposite, then the primary wiring needs to be corrected.

Once all of these preliminary checks have been completed, then the electrical troubleshooting of the system can begin. Use the manufacturer's sequence of operation, connection wiring diagram, ladder diagram, and any trouble "trees" that are available, along with a good multimeter.

## FINAL POINTERS

When testing the power supply, make sure that the module runs on 24 V.

Modern heating equipment is complex enough, so it's necessary to keep transformer leads identified and properly wired:

- "C" on the transformer goes to 24 V (GND);
- "C" is connected internally (in the module) to both burner GND and MV/PV.

If connected wrong, the transformer can be burned out, because one side of the transformer is grounded somewhere in the control wiring. You can check this by measuring the voltage from each transformer terminal to ground; 24 V = hot side (R); 0 V = ground side (C).

## DEFINITIONS

**Continuous retry** – A 90-sec trial for ignition with a 5-min shutoff before retry.

**Interpurge** – The 30-sec period between trials for ignition, when both the gas valve and igniter sources are turned off and the inducer is on, allowing unburned gas to escape before the next trial. (Occurs only if ignition was not successful during the previous trial.)

**Lockout** – At the end of a trial period, this safely shuts down all systems. It must shut off and then re-establish electrical power for retry. Non-lockout - Also called continuous trial for ignition; the system keeps sparking until ignition is established.

**Postpurge** – The time after burner operation when the blower continues to run, to force any residual products of combustion from the chamber.

**Prepurge** – The time when the system is not up and trying for ignition. During this time, any residual products of combustion will be forced out of the chamber. When replacing the module, if the time you need is not available, go to the longer prepurge, never the shorter.

**Response time** – For a thermocouple, about 180 sec; for intermittent ignition systems, 0.8 sec.

**Self-healing** – (Special feature on some integrated fan controls.) If the system fails to light on the first try because of an open limit, before the second trial, the induced-draft blower and system fan will come on for 180 sec, then start the ignition sequence again. If the first ignition attempt fails during a normal heating cycle sequence, the control will activate a “self-healing” sequence over the temperature correction cycle before the next trial for ignition.

**Shutdown** – This means that it will retry without having to interrupt power.

**Soft lockout** – If the burner fails to light after three tries, the system will shut down, wait 60 min (some systems could be longer, up to 3 hrs); it will then go through an ignition sequence again. This will repeat indefinitely.

**Timed trial for ignition** – The time a system will try for ignition; this varies with the manufacturer. When replacing, always go to the lesser time if the module with the correct time is not available.

## invensys®

Controls Americas  
515 South Promenade Avenue  
Corona California 92879-1736 USA  
www.icca.invensys.com  
©2006 Invensys Controls Americas 2/06 - #150-1981

**For Customer Service:**  
Telephone +1 800 951 5526  
Facsimile +1 800 260 7299  
iccacustomerservice@invensys.com

**For Technical Service:**  
Telephone +1 800 445 8299  
Facsimile +1 800 260 7242  
technicalservice@invensys.com